

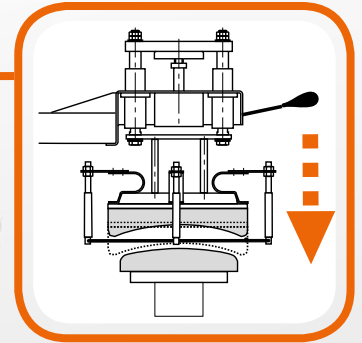

Sfumatura regolabile.  
Adjustable pressure.



Pressatura verticale  
Vertical pressing



Programmatore touch-screen a colori TCW 7" con porta USB e Wi-fi removibile  
Full color touch screen programmer TCW 7" with USB and Wi-fi

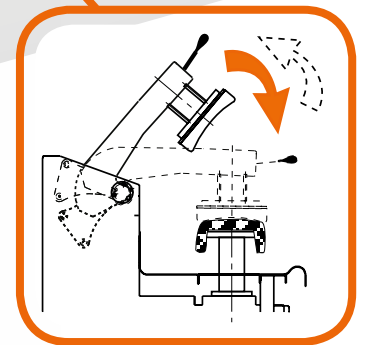

Velocità di avvicinamento e apertura della forma superiore performante.  
Higher speed of the arm during approach and opening.



**555.04.0990**

Pressa per lo stiro della gonna  
Macchina da stiro elettropneumatica con funzionamento manuale/automatico, forme riscaldate a vapore piano superiore vaporizzante montato su braccio a bilanciere con possibilità anche di discesa verticale e regolazione posizione di sfumatura, completa di salvamani elettronico.  
La forma 0990 e simili consentono lo stiro della gonna che avviene ruotando più volte la gonna.



**555.04.0990**

Machine for skirt pressing  
Electro-pneumatic pressing machine, manual or automatic operated, with steam heated shape fitted on movable arm. Suitable for skirt finishing. Possibility of adjustable sponging position with vertical approach. Top shape fitted with head safety device. The shape 0990 and similar shapes allows to finish the skirt rotating it few time until the pressing is completed.

**Technical details**

- 555.** **Dimension:** (mm W x H x D) 1100 x 1265 x 1000 | **Weight:** 240 Kg  
**Compressed air:** pipe connection 1x ø10 mm | **Pressure** 6 ATE | **Consumption** 60NL/min  
**Electric power:** 0,25Kw | **Consumption** 0,19Kw/h  
**Steam:** pipe connection 1x ø1/2" GAS | **Pressure** 5 ATE | **Consumption** 10Kg/h

